



KONČAR

Končar Electronics and Informatics, Inc

KONTRAC PN 35 DC Auxiliary converter for trams



KONTRAC PN 35 DC for trams

KONTRAC PN 35 DC is used as the auxiliary power supply converter in tram vehicles. It converts 600 V_{DC} or 750 V_{DC} line voltage into three-phase AC voltage intended for supplying of tramcar's air-conditioning unit, single-phase AC voltage for service purposes and DC voltage intended for charging batteries and supplying of all DC consumers onboard the tram.

KONTRAC PN 35 DC consists of:

- Input filter
- Pre-charging circuit
- Buck converter
- Resonant converter
- Three-phase inverter
- Sinus filter
- Battery charger
- Cooling system
- Control unit

Features

- Input line voltage 600 V_{DC} or 750 V_{DC}
- Latest IGBT technology
- Galvanic insulation input / outputs and among outputs
- High-frequency resonant inverter
- Easy maintenance
- Light and compact design
- Roof mounting
- Extended ambient temperature range from -40 °C to +40 °C

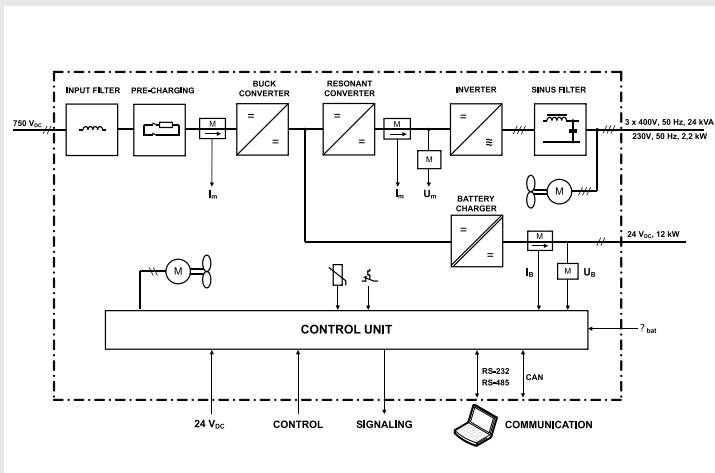

Block diagram of the converter

Digital control unit

Digital control unit (DCU) is based on proprietary embedded control platform which has been used for years in our rail solutions (locomotives, coaches, trams, EMU, DMU).

DCU is responsible for all sequence control, regulation, protection, communication, supervision and diagnostics tasks.

Diagnostic and visualization

Proprietary powerful diagnostic and visualization tool (ZZT) is compatible with all our platforms through many generations of control electronic solutions.

Remote diagnostic functions allow monitoring of all intelligent units from one connection point.



"Končar" tram vehicle in Zagreb

Basic technical data

Input voltage:	600 / 750 V _{DC}
AC outputs:	3 x 400 V, 50 Hz, 25 kVA 230 V, 50 Hz, 2.2 kVA
DC output:	24 V _{DC} , 12 kW
Cooling:	Forced air-cooling
Size (L x W x H):	1770 x 700 x 520 mm
Weight:	300 kg
Mounting position:	Roof
Connecting interface:	CAN / MVB / Ethernet

Mechanical design and cooling system

The converter is designed for roof mounting with IP54 protection. High-frequency converter enables use of transformers and chokes with smaller dimensions and mass which significantly decreases mass and size of the converter, resulting in minimized vehicle weight. Converter box is made from stainless steel and is intended for use in extended ambient temperature range from -40 °C to +40 °C.

The converter is efficiently cooled by forced air.

Application example

KONTRAC PN 35 DC is mounted on the roof of 100% low-floor Končar tramway TMK 2200 that operates in City of Zagreb, the capital of Croatia. The tram car series TMK 2200 is distinguished by its modern and attractive design, superior technical characteristics and comfortable ride.

These modern vehicles significantly contribute to efficient and comfort public transport in City of Zagreb.



Končar Electronics and Informatics, Inc

Fallerovo šetalište 22, 10000 Zagreb, Hrvatska
Tel.: +385 1 3655 766, fax: +385 1 3655 550
E-mail: transportation@koncar-inem.hr
www.koncar-inem.hr

