

KONTRAC PN30AC / PN50AC Auxiliary converter for substations

KONTRAC PN30AC / PN50AC is a trackside auxiliary power supply converter fed by 25 kV, 50 Hz overhead line. It is used in order to supply various loads inside the substation facilities (power supply for integrated lighting and information systems, railway signaling and protection systems, etc.). Overhead line might generate spikes, sags and surges caused by the current drawn from locomotives. Those are likely to damage the input stages of conventional converters.

In order to provide a trackside noise filtered power source, we use the same technology as for our rolling stock converters.

The converter is primarily intended to be used as a backup energy source (in case of power outage from the distribution network). However, in projects where poor or no distribution network is available at site, this converter can be implemented as a primary power source as well.



FEATURES:

- Rolling stock converter technology
- Robust input rectifiers
- Nearly sinusoidal input current, in phase with the input voltage
- Output transformer ensures galvanic isolation
- Sine wave output filter
- EMC output filter
- Easy maintenance
- Modular design of power unit
- Air cooling

KONTRAC PN30AC CONSISTS OF:

- Input contactor and precharging circuit
- Input rectifier, chopper and inverter power module
- Output sine wave filter
- Output EMC filter
- Output transformer
- Air ventilation system
- Control unit

BASIC TECHNICAL DATA

Input voltages	230 V, 50 Hz over transformer 25 kV / 230 V
Minimum input voltage	160 V (equivalent to 17,5 kV of overhead line voltage)
Maximum input voltage	270 V (equivalent to 29 kV of overhead line voltage)
AC output	3 x 400 / 230 V, 50 Hz, 30 / 50 kVA
Cooling	Forced air-cooling
Size (W x D x H)	600 x 600 x 2000 mm / 800 x 800 x 2250 mm
Weight	504 kg / 760 kg
Mounting position	Substation
Connecting interface	CAN / MVB / Ethernet

Two converters KONTRAC PN30AC installed in Drivenik Railway Station, Croatia



DIGITAL CONTROL UNIT

Digital control unit (DCU) is based on proprietary embedded control platform which has been used for years in our rail solutions (locomotives, coaches, tramways, EMUs, DMUs). DCU is responsible for all sequence control, regulation, protection, communication, supervision and diagnostics tasks.

DIAGNOSTIC AND VISUALIZATION

Proprietary powerful diagnostic and visualization tool (ZZT) is compatible with all our platforms through many generations of control electronic solutions. Configurable event-driven data logging and event recording is integrated in the control electronics.

MECHANICAL DESIGN AND COOLING SYSTEM

The converter has IP54 mechanical protection and it is designed for mounting inside the traction substations. The modular design of the power module allows an easy maintenance. The converter is efficiently cooled by forced air.

APPLICATION EXAMPLES

The converters KONTRAC PN30AC and KONTRAC PN50AC are installed on several Railway Station in Croatia. The converters are used as a primary auxiliary power supply of all single-phase and three phase AC consumers. The input circuits of the converters are resistant to spikes, sags and surges in overhead line caused by the current drawn from locomotives. The converters KONTRAC PN30AC and KONTRAC PN50AC are also installed in several Railway Station in Croatia and Center for remote control of electric system for rail transportation in Croatia where it is used as a backup auxiliary power supply in case of power outage from the distribution network.

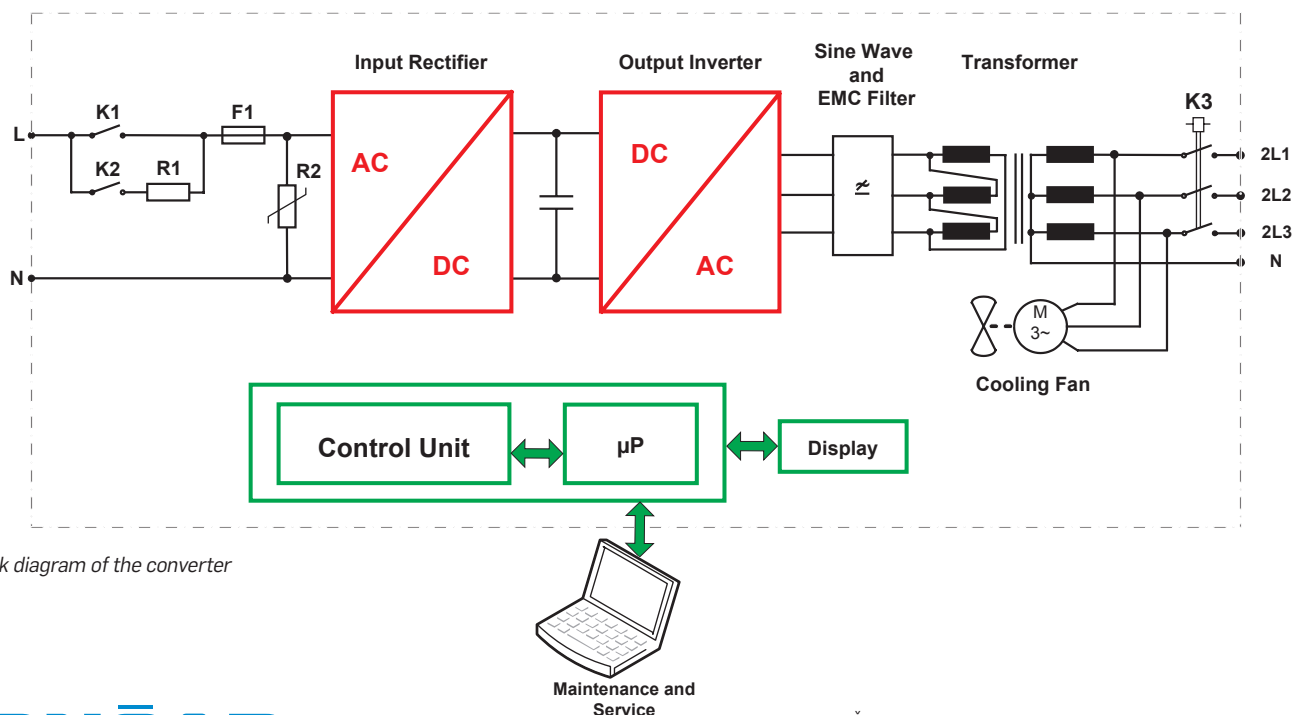

Block diagram of the converter